

# Hydraulic Caliper Disc Brakes BAC Series

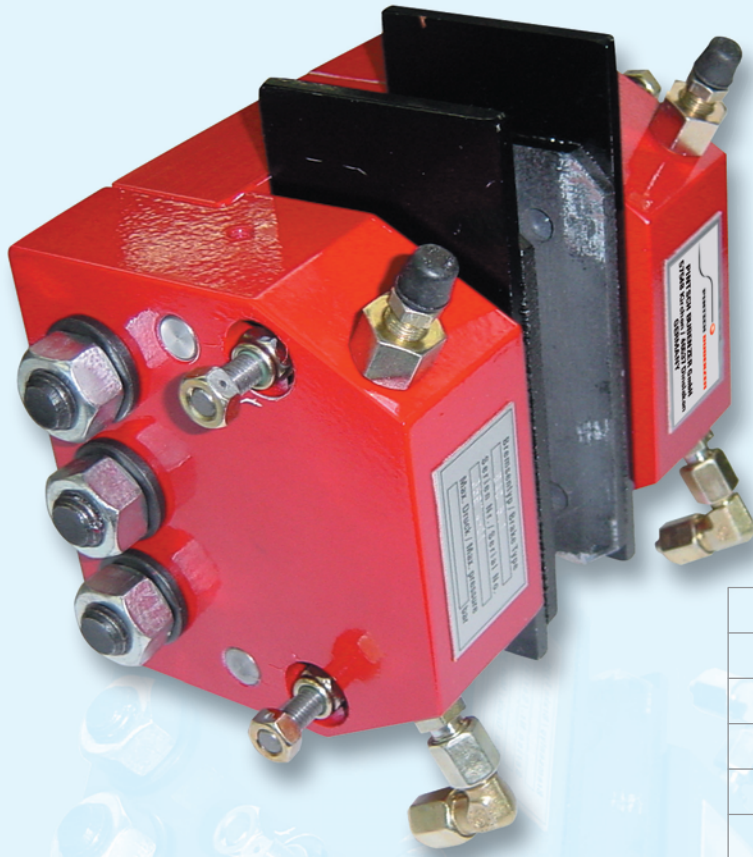

**B**



**PINTSCH BUBENZER**  
is certified according to  
DIN EN ISO 9001:2000

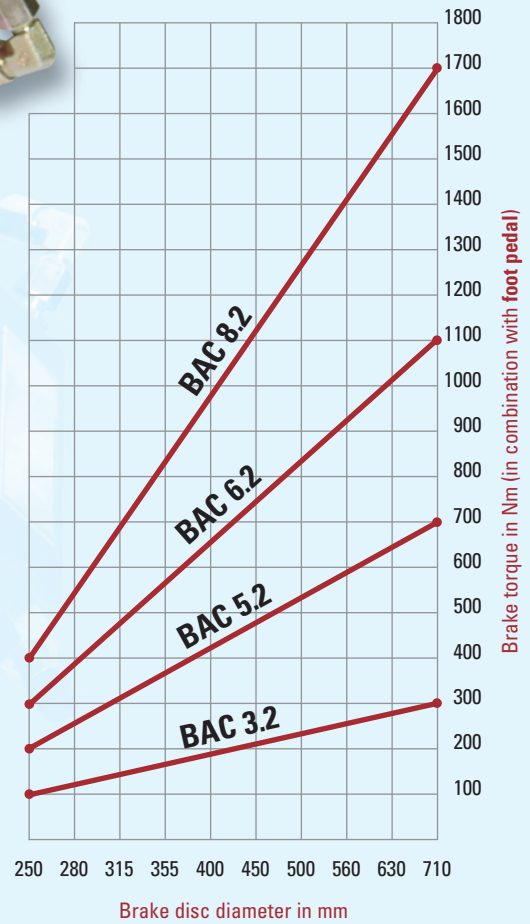

Direct-acting braking



Hydraulic/Pneumatic



Robust



Compact

## Main Features

Brake <u>hydraulic</u> or <u>pneumatic</u> applied, spring released
<b>No failsafe function!</b>
Adjustable retraction springs
Automatic wear adjusting brake linings
Organic, non-asbestos linings
Operation by foot pedal or separate hydraulic power unit
Airgap between brake pad and disc up to 2 mm per side

## Options

Limit switch release control
Sintered linings
Complete piped supports for one or more calipers
Hydraulic power units
Pneumatic power units
Hydraulic foot pedals
Brake discs

## Applications

Stopping and/or holding of fans, blowers, wind turbines, coilers, crane slewing and travel gears etc..
--



### Please Note

We supply a detailed operating manual with every order. Nevertheless, we would point out that brakes are only as safe as the servicing and maintenance performed while they are in operation. The guarantee for the correct functioning of our brakes is therefore only valid if the user adheres to the German DIN standard 15434 part 2 (drum and disc brakes, servicing and maintenance in operation), or to comparable standards in his own country.



### PINTSCH BUBENZER Service

This includes the verification of the brake selection, if required. A detailed questionnaire is provided for this purpose. Installation and commissioning on site is possible by PINTSCH BUBENZER service engineers. Drawings as DWG/DXF files for your engineering department are available upon request.

# Disc Brake BAC

Dimensions and technical data



Rev. 11-03

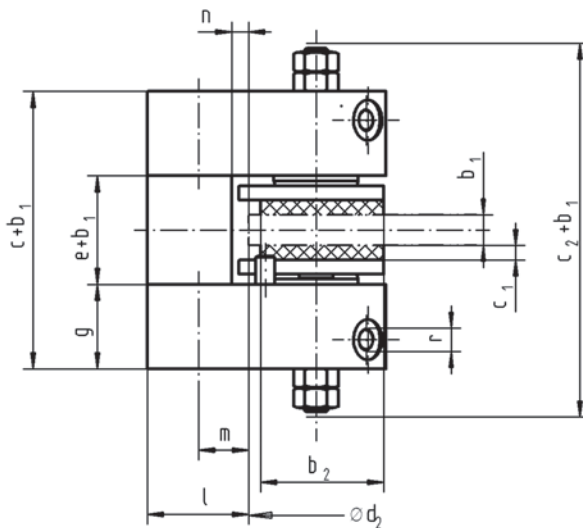
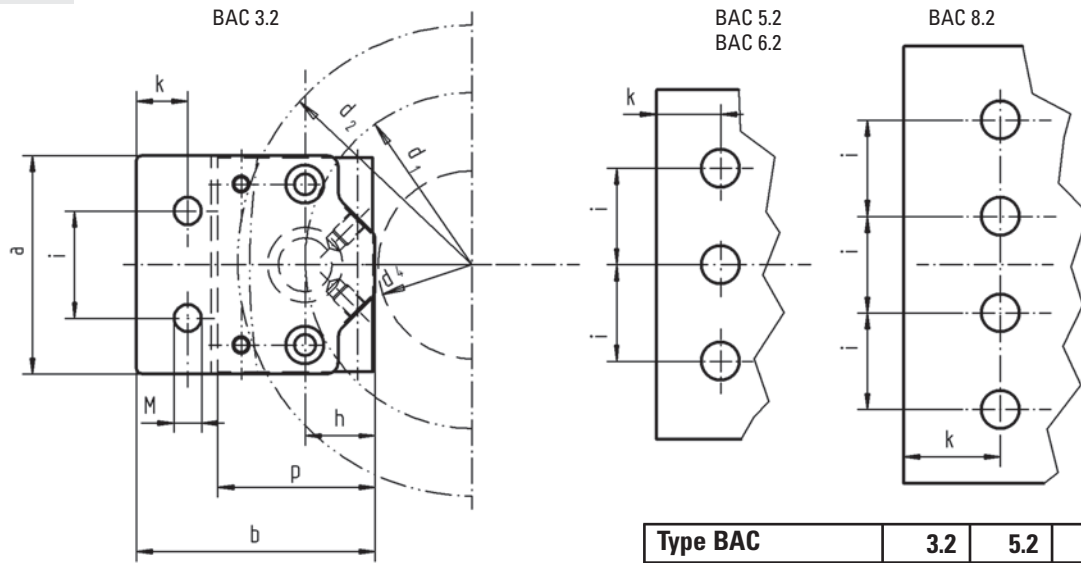

All dimensions in mm  
Alterations reserved without notice

**Brake torque  $M_{Br}$  in Nm =  $F_A$  (kN) x  $\mu$  x  $d_1$  (mm)**

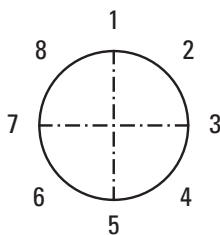

Please indicate mounting position in case of order.

Type BAC	3.2	5.2	6.2	8.2
a	102	130	163	204
b	100	120	141	182
b <sub>2</sub>	51	63	82	95
c	103	137	156	178
c <sub>1</sub>	6	6	8	8
c <sub>2</sub>	143	164	188	244
g	35	50	54	65
h	30	39	46	60
i	50	35	45	45
k	24	26	30	45
l	42	47	50	72
m	16	19	20	27
n	7	7	6	10
p	62	79	97	120
r	1/8"	1/8"	1/4"	3/8"
e	33	37	48	48
Bolt $\varnothing$	M10	M12	M16	M16
Bolt material	10.9	10.9	10.9	10.9
Tighten. torque, Nm	69	120	295	295
Pad surface cm <sup>2</sup>	46,5	74	118	168
Piston surface cm <sup>2</sup>	9,5	19	33	50
Max. pressure bar	90	120	120	120
Max. stroke mm	1,6	2	2	2
Weight (kg)	8	10	20	35
<b>Factor</b> f <sub>1</sub>	0,033	0,067	0,115	0,175
<b>Factor</b> f <sub>2</sub>	60	70	90	100

Data per caliper half

f<sub>1</sub> = Factor, see table  
f<sub>2</sub> = Factor, see table  
d<sub>2</sub> = Disc diameter in mm  
p<sub>vorh</sub> = Existing operating pressure in bar



# Foot Pedal

for hydraulic brakes



Rev. 09-02

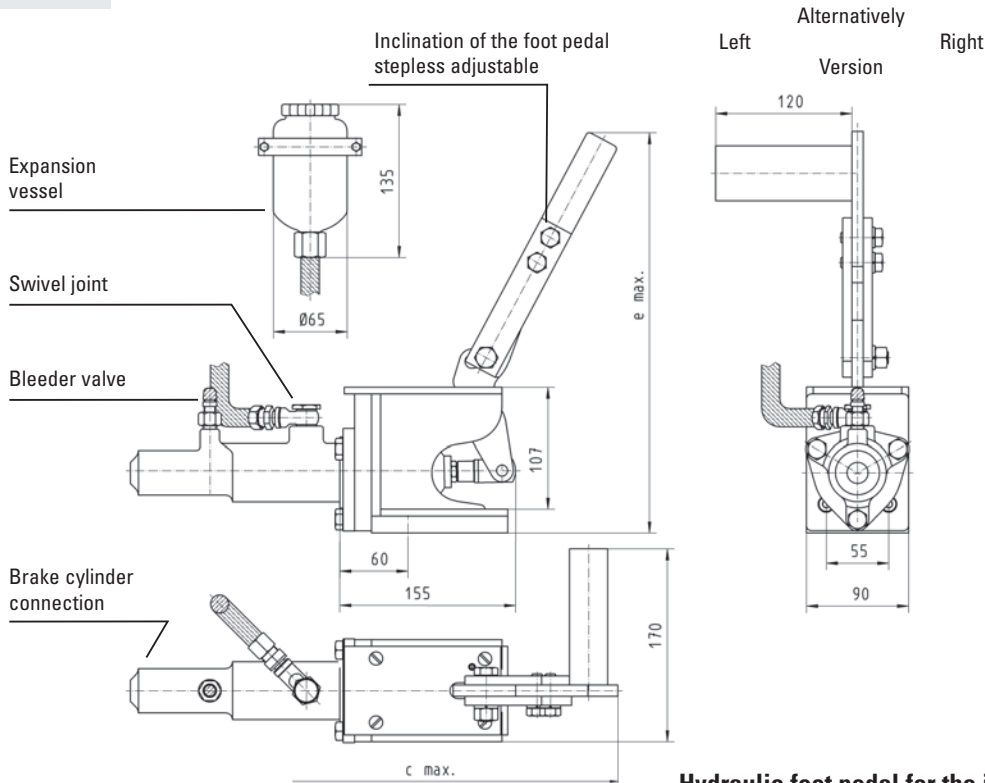

### Hydraulic foot pedal for the installation in cabin floors

Execution	a	b	c <sub>Max</sub>	d	e <sub>Max</sub>	Weight <sub>kg</sub>
1 with simple main cylinder	300	60	485	6	330	6,8
2 with two step cylinder	355	40	540	21	345	9,8

**In order to operate two brakes synchronously by one foot pedal, the pipe connections from the foot pedal to each brake must be of the same length.**

Scope of supply:

- a) Brake with built-in slave cylinder, bleeder valve and straight screw union for the connection of:
- b) One high-pressure hose, 500 mm long, with straight screw union, for connection to the pressure line.
- c) Expansion vessel with straight screw union.
- d) Foot pedal with attached master cylinder, a swivelling screw-fitting for the connection of the expansion vessel and a bleeder valve.

PistonØ	ca. Pressure (at 150N foot force)
25,4	24 bar
28,5	18 bar
31,8	15 bar
38,0	10 bar

- e) Two high-pressure hoses, 300 mm long, for the connections of the master-cylinder pressure line and slave-cylinder pressure line to the expansion vessel. All the screw unions are arranged for pipe outer dia 10 mm. Pipes and other connection elements are not scope of supply but can be supplied if desired.



Please observe the notes on the following page for the piping and commissioning of the system

# Foot Pedal

Notes on the piping and commissioning



Rev. 09-02

## General remarks:

Only brake fluid as specified in SAE J-1703e and DOT3 / DOT4 may be used. The use of even slight additions of hydraulic fluid or other mineral oils (residues in unclean pipework) leads in every case to the destruction of the seal elements and invalidates any guarantee granted by the manufacturer.

### 1) Master Cylinder

This cylinder may only be installed in a horizontal position, with connection on top for the expansion vessel (swivelling screw fitting). The high-pressure hose to the expansion vessel must not be kinked downwards but must be laid in a constantly ascending manner.

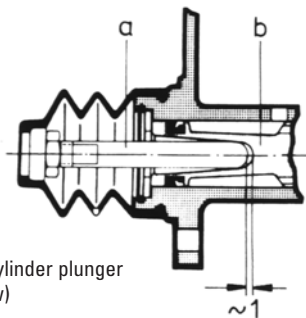

Master-cylinder plunger  
(part-view)

When actuated, the foot pedal is held by a pressure spring in the "off"-position against a stop, whereby there should be about 1 mm play between the plunger (a) and the top of the piston (b). This is to be taken into consideration if the factory setting of the stop has been disturbed.

### 2) Slave Cylinder (Brake)

Installation is possible in any position but the air bleed cock must always be arranged at the highest point. The slave cylinder is to be connected to the pressure line by the high-pressure hose supplied to allow movement of the cylinder when the brake is actuated.

### 3) Pipework

Material: Precision pipe as specified in DIN 2391, annealed and descaled. Dimensions dia. 10x1. Pipe bends are to be fabricated in a pipe bending device to avoid cross-sectional restrictions. After cutting to size and before laying, pipe sections are to be thoroughly flushed out (spirit) and blown through.

If possible, pressure lines are to be laid with a slight slope. If air pockets through ascending and descending loops cannot be avoided, a bleeding facility must be provided at the highest point.

### 4) High-pressure hoses

These hoses must be resistant to brake fluid. They must not be painted and are to be shielded from ambient heat.

### 5) Brake fluid

The brake fluid assures operational reliability down to -40°C. Depending on the quality, the wet boiling point (after water has been absorbed from the air) is between 140 and 155°C.

### 6) Filling and bleeding of the system

#### a) without filling and bleeding unit

Fill expansion vessel and in the subsequent filling and bleeding operation ensure that there is always sufficient fluid in the vessel by topping up. The air from the line to the master cylinder rises automatically when the line has been laid correctly. Press the foot pedal right down on the stop once or twice and with the pedal fully actuated first bleed the master cylinder. Close the bleeder valve.

Then open the valve at the slave cylinder (1-2 turns), fit transparent bleed tube and place other end in a receptacle. Pump foot pedal until air bubbles are no longer seen. At the same time, check the level of fluid in the expansion vessel to ensure that no air can be sucked in!

Close bleeder valve and actuate brake several times via the pedal. Then repeat bleeding procedure. The fluid pumped through during the bleeding procedure should not be reused.

#### b) with filling and bleeding unit (ATE, FAG or similar)

Small, moderately priced units are available on the market which can be connected to the expansion vessel and force the fluid under pressure through the system. Through the flexible separation of fluid and compressed air, the two elements cannot affect each other.

Advantage: The complete procedure can be carried out by one person only. Filling and bleeding will be quicker, safer and more straight forward. The filling and bleeding units come with operating instructions which must be followed exactly when working with such units.

B