

# MOOG

Servo Electronics Products



# Customize your Complete Control System with Moog Servo Electronics

Our Eurocards, Snap Trac electronics and DIN Rail modules provide general purpose solutions to a variety of electrohydraulic servocontrol needs. Electronics selected from the standard assortment can be arranged to handle the most complex systems.

The next several pages illustrate several basic servocontrol systems. Most of these applications highlight the use of one or two circuit cards, in addition to the basic servoamplifier. Additional cards may be used to handle multiples of the basic types of servocontrol illustrated here. When more than three servoloops are required, we recommend using our Eurocard electronics.

Snap Trac circuit cards and the Eurocard rack are intended for mounting within an electrical equipment cabinet that has adequate cooling and environmental protection. Outdoor installations should have a sealed NEMA 4 or equivalent cabinet.

The recommended operating temperature range of Moog servo electronics is -20°C to 50°C (-4°F to 122°F).

All AC operated circuits accept both 105-130 Vac and 210-230 Vac, 50-60 Hz, and are designed to supply DC voltages to other peripheral circuits. Consult the Factory for mobile (DC) operation of AC designated cards.

## EUROCARD

Eurocards are versatile, plug-in electronics that are well suited for use in multichannel servosystems or complex control systems which require a variety of functions. Standard 19 inch racks accommodate a power supply, plus up to nine individual circuit cards such as a servoamplifier, a signal conditioner or an oscillator/demodulator. Eurocards are available for 115V AC and 230V AC operation or external DC power supply.



## SNAP TRAC

Snap Trac electronics are a reliable, low cost option for industrial equipment design. These modular circuit boards provide multifunction servocontrol system capability, and snap into position on to PVC track, allowing for convenient installation, maintenance and replacement. Snap Trac cards are available for 115 V AC and 230 V AC operation and are typically recommended for use in systems having one or two channels.



## TRANSDUCER

Position, pressure and rotary transducers are available for additional control of a servosystem. The two standard position transducer options are a magnetostrictive design with lengths to six feet and beyond, and short stroke DCDT's and LVDT's ( $\pm .2$  to 3 inches). Single port and differential pressure transducers are also available. Standard tachometers for velocity feedback and rotary potentiometers (340° total range) or resolvers for position feedback are available for rotary servodrives. Transducer models are available with housings for external mounting to cylinders or machine control elements.



# MOOG

## VALVE TESTER

The Moog Valve Testers are a cost effective method of evaluating valves in the field. They provide a "Go/No-Go" analysis of Moog Proportional and Servovalves to determine if a valve requires servicing. There are five models to choose from, each with different levels of capability and flexibility.



## DIN RAIL MOUNT MODULES

DIN Rail electronics are great for use in enclosures where space is limited. All of these modules are CE marked and require a 24 VDC supply. The modules mount to a standard 35mm DIN rail for easy installation and removal.



## Eurocard

## PHYSICAL ARRANGEMENT

The Moog NF127-101A1 19" rack card cage accommodates the NF120 series Eurocards. The rack card cage is completely assembled with guides installed for nine cards, in addition to one location reserved for the power supply. Controls and test points are accessible on the front panel of each Eurocard.

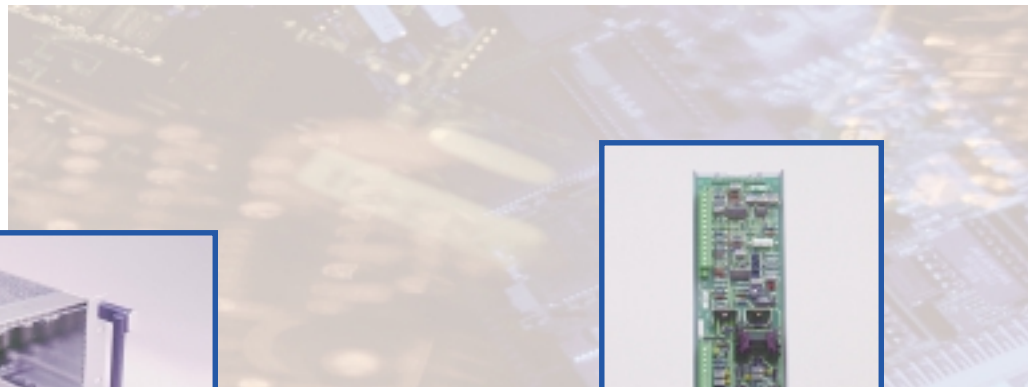

## Snap Trac

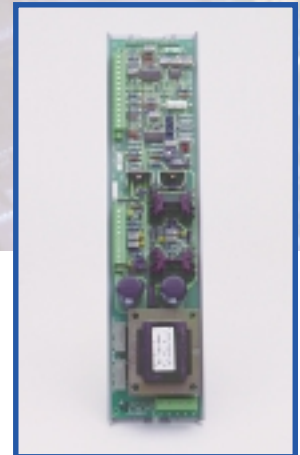

Moog Snap Trac Electronics fit Curtiss type TR-3 plastic (PVC) track, which is available in four foot lengths. The cards are designed to snap into position anywhere along the track length. The track/card combination can be mounted inside a common electrical enclosure or equipment panel.

The Snap Trac cards are made of epoxy glass boards varying in length from 2.8" to 14.0". Twenty-turn trim pots are used throughout the designs. High quality plug-in screw connectors facilitate installation and serviceability. Component standoffs provide flexibility for custom circuit modification. Test points are conveniently available on each card.

# Eurocard Product Line

FUNCTION	MODELS	FEATURES
Servoamplifier	<b>M122-811:</b> Intermediate Servoamplifier	<ul style="list-style-type: none"> <li>• Opto-Isolated PLC outputs</li> <li>• Front panel LED array indicators for CMD &amp; Feedback</li> <li>• Pressure/load compensation control</li> <li>• <math>\pm 50\text{mA}</math> max output</li> <li>• Test Mode Functions</li> </ul>
	<b>G122-202A1:</b> Enhanced Servoamplifier	<ul style="list-style-type: none"> <li>• PID Control</li> <li>• 10 to 100mA Output</li> <li>• Dither Select</li> <li>• Front Panel LED Indicators &amp; Test Points</li> <li>• 4-20mA to 0-10Vdc Converter</li> <li>• Ramp Generator</li> <li>• CE-Mark</li> <li>• FCC Part 15 Compliant</li> </ul>
Servocontroller	<b>N122-001</b>	<ul style="list-style-type: none"> <li>• Outer Loop PID control - jumper select</li> <li>• Inner Loop Gain Potentiometer</li> <li>• Current Limiter/Front Panel Test Points</li> <li>• Servoamplifier with Oscillator/Demodulator</li> <li>• Configuration jumper select options</li> <li>• Large Exciter Frequency range</li> <li>• Independent Gain Potentiometers</li> </ul>
Velocity Controller	<b>M122-815</b>	<ul style="list-style-type: none"> <li>• 12-Bit PLC compatible digital command</li> <li>• 4-Bit PLC compatible card select address</li> <li>• Feedback from pulse pick-up or analog Xducer</li> <li>• ATSP output to PLC indicates system is at speed</li> <li>• Global ramp input for ramping of multi-axis</li> <li>• Front Panel LED's/Test Point monitoring</li> </ul>
Power Supply	<b>E128-210:</b> Standard Moog Power Supply	<ul style="list-style-type: none"> <li>• Regulated DC Power Supply Section</li> <li>• Front Panel LED Indicators/Test Points</li> <li>• Front Panel On/Off Switch &amp; Fuses</li> <li>• +5Vdc Regulated Option</li> </ul>
	<b>M128-001-A002:</b> Enhanced power supply	<ul style="list-style-type: none"> <li>• 120/240Vac power required</li> <li>• <math>\pm 350\text{mA}</math>; low voltage level alarm</li> <li>• Front panel test points and LED's for <math>\pm 15\text{Vdc}</math> (for 4-slot M127-105 Card Frame)</li> </ul>
	<b>G128-001-A001 / -A002:</b> similar to NF128-201, but has CE mark and switching power supply. Does not have 5V option	<ul style="list-style-type: none"> <li>• CE-Mark conformance</li> <li>• Compatible to Moog 120 series</li> <li>• Input voltage selection by fuse change</li> <li>• Low ripple and noise</li> <li>• High temp range</li> <li>• Front Panel LED's/Test Points</li> <li>• Power-Failure relay output</li> </ul>
Exciter/Demodulator	<b>NF123-204A1</b>	<ul style="list-style-type: none"> <li>• Adjustable Exciter frequency/amplitude</li> <li>• Demodulator for improved accuracy</li> <li>• Adjustable bias for fast calibration of Xducer null</li> <li>• Front Panel Pot adjustments/Test Points</li> </ul>

## BENEFITS

## APPLICATIONS

## COMMENTS

- Provides any combination of PID control
- Capability for simple V-I converter configuration
- On-Board relay for remote monitoring / control
- Provides dither if needed
- Can run in either Current or Voltage Mode

- Ideal for installations with limited technical support

- Forward compatible replacement with NF122-202A001
- Requires DC Power Source
- Multi-Control Function availability

- Closed-Loop control of 3-stage servovalve using LVDT spool position feedback sensors
- Current Limiter - rate limit control possible
- Excitation/Demodulation to close inner loop of servovalve spool while providing PID control of outer loop servoamplifier section

- Drive servovalves or proportional valves in closed-loop servosystem applications
- Used as a simple V-I Converter to drive servovalves
- For system requiring PID control
- SPDT relay used for integrator reset, signal switching, high/low voltage detection or other function

- Ease of field calibration
- Adjustable Exciter Frequency / Amplitude
- Linear Frequency Response

- Can be used in multi-axis systems
- Jumper selectable options on card enable a wide variety of applications to be met
- Front Panel access provides ease of troubleshooting
- Capable of monitoring performance of the loop
- Status outputs to PLC allow automatic control

- 3-Stage servovalve control
- Closed-Loop position control systems
- Systems using LVDT's as position sensors & 2-stage servovalves

- Companion 'monitor card' is M123-807 to monitor data bus and provide 'global' ramp

- Provides power to circuit cards of the NF/F120 Series of Eurocard products
- Mounts directly in a special slot located in a 19" Rack
- May be configured in one of 4 Model options

- Addressable DAC Servoamp for multiple speed or position axis
- PLC interface compatible for various applications and automatic control

- 115/230Vac power required
- $\pm 15\text{Vdc}$  @ 1.0Amp Max Regulated Output
- $\pm 24\text{Vdc}$  @ 1.5Amps Max Regulated Output
- $+5\text{Vdc}$  @ 3.0Amps Max Stabilized Output option
- Load Regulation:  $\pm 80\text{mV}$  Max (0A to Full Load)
- Forward compatible replacement to MOOG I20 Series

- Use where CE-Mark compliance is required
- Designed in-circuit protection including 'short circuit', thermal and input transients
- Meets 'Safety' directives: EN60950 / IEC950
- Meets 'EMC' directive: EN50081-2 / EN50082-2

- Designed to provide power to other Eurocards within a standard 19" Card Rack
- Used for both 115V or 230Vac applications
- $+5\text{Vdc}$  required for logic circuits
- May be used in 3-card rack applications
- Used as power source for custom systems

- Replacement for D128F/G012-A001 and D128-H/G010-A001

- Circuitry to 'excite' an LVDT or 'demodulate' output of an LVDT to a usable form
- Output DC voltage is 'proportional' to displacement of the LVDT 'core'

- Use with linear variable differential Xfmr (LVDT) in high performance closed-loop systems
- LVDT Position Decoding

- Adjustable Exciter frequency from 100 to 2500 Hz
- Adjustable Exciter amplitude from 2-11Vp-p
- Forward compatible replacement with F123-204-A001

continued next page

## More Eurocard Product Line

FUNCTION	MODELS	FEATURES
Signal Conditioner	NF123-211A1	<ul style="list-style-type: none"> <li>• Jumper select Gain Ranges</li> <li>• Configurable Summing Amplifier</li> <li>• Regulated DC Power Supply</li> <li>• Front Panel Pot adjustments/Test Points</li> </ul>
DC Level Detector / Comparator	NE123-212-1	<ul style="list-style-type: none"> <li>• Dual-Channel Window Comparator</li> <li>• 4-Inputs per Channel/Summing Input Amp</li> <li>• Adjustable Time Delay</li> <li>• Front Panel LED Status Indicators</li> </ul>
Ramp Generator	NF123-203A1 Integral on G122-202A1	<ul style="list-style-type: none"> <li>• Ramp Control - remote adjustment of slopes</li> <li>• Output Smoothing - Adjustable Potentiometers</li> <li>• Jumper select options</li> <li>• Front Panel Adjustments/Test Points</li> </ul>
I-V Converter	N/A Integral on G122-202A1 (4-20mA to 0-10Vdc)	N/A
Dither Generator	Integral on G122-202A1	N/A
Auxiliary Amplifier	NF123-158B1	<ul style="list-style-type: none"> <li>• 4-Channel Independent Jumper Select options</li> <li>• Circuit Configuration options (ex. I-V converter)</li> <li>• Front Panel Pot Adjustments/Test Points</li> <li>• 4-Input Summing Amp</li> </ul>
Test Module	NF123-202A1	<ul style="list-style-type: none"> <li>• DC Power Supply</li> <li>• Input Voltage Ranges</li> <li>• Input Selection - Rotary Switch on Front Panel</li> <li>• Range Selection - Automatic</li> </ul>
Relay Card	NF123-207A1 / NF123-208A1	<ul style="list-style-type: none"> <li>• NF123-207: 1-SPDT &amp; 1-4PDT relay; active lo/hi circuitry for both relays; LED front panel indicators</li> <li>• NF123-208: Front Panel adj/Test Points; jumper select I/O voltages; relay switching control</li> </ul>
Mounting Hardware/ Misc / Card Frames	NF127-101A1: 9-Slot Card Frame - 19" wide B52616-1: 1-Slot Max Card Holder A81750-1: Extender Test Card T127-401: 3-Slot Eurocard Enclosure M127-105-A001: 4-slot	<ul style="list-style-type: none"> <li>• Standard 19" Card Rack Mount Module Cage</li> <li>• 1-Slot reserved for Power Supply/9-Card locations</li> <li>• Terminal Strip for main Power Connections</li> <li>• Terminal Strip for output voltage of P/S</li> <li>• Contact rating: 1A @ 250Vdc</li> </ul>

## BENEFITS

## APPLICATIONS

## COMMENTS

- Circuitry to supply DC power to 2-transducers and to amplify the outputs of the transducers
- Used to generate a voltage that is proportional to the difference between the 2-conditioned Xducer signals

- Use with pressure Xducers, strain gages & load cells in high performance servosystems
- Transducer Excitation

- Dual-Channel module
- Differential Inputs

- Preset Hysteresis
- Transistor Output option for customer use
- Configurable relay for latch/reset operation
- Up/Down Integrator - eliminates effects of transients
- Dual Form-C relay for remote monitoring

- Use of Ch1 to monitor voltage for error voltage monitoring / Ch2 monitors reg power supply output
- Monitoring input error voltage from 0 to +10Vdc, supply voltage such as +5 ±0.5Vdc and on/off switching output modes tripped at set DC levels such as ±2Vdc

- Independent option from same card forward compatible replacement for E123-212-001
- Provides a variable 'window' width detection circuit on each of 2-channels remote sensing/ monitoring or alarm for customer use

- Provides independent control of accel/decel
- Transforms a 'step' input into a 'ramp' output
- Changes amount of rounding in curves for smoothing
- Standoffs for ease of component configuration

- Velocity Control in Position Servo
- Acceleration Control in Velocity Servos
- Control 'jerk' in a Force Servo

- Forward compatible replacement for F123-203-A001
- Wide Slope Range Adjust
- Ease of testing, set-up & monitoring of signals
- Compatible with remote-mounted potentiometers for slope adjust

N/A

N/A

N/A

N/A

N/A

N/A

- Provides quick access to Gain, Scale & Bias Pots
- Accommodates special needs of unique control systems
- Provides Control Engineer with a tool to design custom circuits NOT available in standard cards
- Allows precise adjustment with 20-turn Pots

- Typical applications include: buffers, summing amplifiers, differential amplifiers, oscillators, compensators, dither generator, I-V Converter, etc.
- Special applications: ±1Vdc Input command to ±10Vdc (non-inverting) output signal

- Forward compatible replacement for F123-158BI
- I-V conversion including 4 to 20mA Input Command to 0 to +10Vdc Output, -10 to +10Vdc Output & 0 to -10Vdc Output
- Card Set-Up instruction details are available on several of the outlined example configurations - Consult Moog Applications

- Designed to check 12-different voltages pre-wired on the NF127-101 Motherboard Terminals
- Jumper Select Options

- Card facilitates system adjustments, modifications or maintenance

- Forward compatible replacement for F123-202-A001 Test Module Card

- Both designed as relay cards allowing adjustment of output voltage & easily accommodates setting of 4-set point voltages
- Voltages can be switched via external relay

- Applications include customer controlled interface for servovalve control application & monitoring
- Set-Point voltages can be used for a control device such as a position or velocity controller

- NF123-207 - Forward compatible replacement for F123-207-A001
- NF123-208 - Forward compatible replacement for F123-208-A001

- Accommodate the NF/F120 Series cards
- Ease of Installing custom control systems
- Ease of card installation/ troubleshooting
- Card extender can be provided for set-up/monitoring
- Provides front panel control of all functions

- Development of custom Control Systems using several cards
- Use of test equipment can be mobile
- Where applications require ease of troubleshooting

- NF127-101A1 - Forward compatible with F123-101A001



# MOOG

# Snap Trac Product Line

FUNCTION	MODELS	FEATURES
Servoamplifier	<b>NI22-142A:</b> Standard Servoamplifier	<ul style="list-style-type: none"> <li>• Jumper Select PID Control/Adjustable Pots</li> <li>• Error-Summing Input Stage</li> <li>• Adjustable Current Limit/Overcurrent Protection</li> <li>• SPDT Relay Section/Jumper Select</li> <li>• Auxiliary Amplifier Section</li> <li>• Additional Inner-Loop Inputs</li> <li>• Requires DC Power Supply/100mA Max Output</li> </ul>
	<b>MI21-823:</b> Enhanced Servocontroller	<ul style="list-style-type: none"> <li>• Monitoring LED's of Power Supply and Valve Drive</li> <li>• Adjust Limit Control of Servovalve Drive Current</li> <li>• Auxiliary Amplifier</li> <li>• I-V Conversion</li> <li>• Dead Band Compensation</li> <li>• Dither</li> <li>• Adjustable Voltage Regulator DC Power Supply Included</li> </ul>
Servocontroller	<b>NI21-132A:</b> similar to NI22-142A, but does include a DC power supply	<ul style="list-style-type: none"> <li>• Same features of NI22-142A</li> <li>• Integral 'fused' DC Power Supply</li> <li>• Can supply DC power to other cards</li> </ul>
Velocity Controllers	<b>MI21-819</b>	<ul style="list-style-type: none"> <li>• Interface directly with PLC/PC</li> <li>• Opto-Coupler &amp; solid state switching</li> <li>• Designed-in Power Supply/0-4, 0 to +18V Command Output</li> <li>• Motion Detector</li> <li>• LED status indicators/Multi-function alarms</li> </ul>
	<b>MI21-828</b>	<ul style="list-style-type: none"> <li>• 12-24Vdc Input; A/D; <math>\pm 100</math>mA Valve Drive Output</li> <li>• Low cost/Simple set-up and operation</li> <li>• Open/Closed Loop Control option</li> <li>• Typical <math>\pm 1\%</math> long term speed accuracy</li> <li>• 100V supply input protection</li> </ul>
Power Supply	<ul style="list-style-type: none"> <li>• Integral on NI21-132A</li> <li>• Integral on MI21-823</li> </ul>	<b>N/A</b>
Exciter/Demodulator	<b>NI23-134</b>	<ul style="list-style-type: none"> <li>• Plug-in connectors for quick installation of card</li> <li>• Test Points access on all critical signals</li> <li>• Component stand-offs for field set-up</li> <li>• Adjustable Multi-turn Control Potentiometers</li> <li>• Three carrier frequencies are available, including 400Hz, 2K Hz and 6K Hz</li> </ul>
Signal Conditioner	<b>NI23-135</b>	<ul style="list-style-type: none"> <li>• Plug-in connectors for quick installation of card</li> <li>• Test Points access on all critical signals</li> <li>• Component stand-offs for field set-up</li> <li>• Adjustable Multi-turn Control Potentiometers</li> <li>• Can accept 2-input signals which can be amplified over a wide range with signal zero adjustment</li> </ul>
DC Level Detector/ Comparator	<b>NI23-136</b>	<ul style="list-style-type: none"> <li>• Three individual inputs available</li> <li>• Settable Input Trip Levels</li> <li>• Fast Transient Response Relay Time</li> <li>• Single Form-C Relay/Fixed Delay</li> </ul>



## BENEFITS

- Diverse application use such as for Force, Position or Velocity Servo Control
- Module contains complete DC Servoamplifier
- Accessible Test Points for ease of troubleshooting
- Stand-offs for ease of component modifications in field
- Ease of tuning capability
- Output serves as an excellent current driver for almost any Moog Servovalve



## APPLICATIONS

- Recommended for closed-loop applications having single or multiple inputs & feedbacks
- Position, velocity or force servo electro-hydraulic servocontrol needs
- Use with unbalanced actuator or 3-stage servo

## COMMENTS

- Requires external regulated power source
- Forward compatible replacement with 122A142 & 122B142
- Can drive servovalves or proportional valves in Open-Loop or Closed-Loop servosystems
- Outdoor installations should have NEMA-4 or equivalent cabinet
- Can be supplied with surface coating on special order to withstand moisture or high humidity

- Same as NI22-142A
- Power Supply capable of driving 2 to 3 servoamplifiers
- Can supply DC to other cards

- Same as NI22-142A
- Closed-Loop Control of a Hydrostatic Drive with Limited Acceleration
- 2-Axis PLC Control Servosystem

- Built-in DC Power Supply
- Forward compatible replacement with 121A132 & 121B132
- Can supply current to 2-temposonics transducers and a servovalve
- Improved Phoenix Type connector interface
- 115/230Vac power required

- Loss of feedback will not cause hardover condition
- Motion detector provides indication to the PLC / panel
- Independent up/down ramp control / on-board or external 0-5V analog velocity signal / manual/auto select by PLC

- Applications for the system include variable speed conveyors for apron feeders, canning lines, ore-handling, batch weighing, auger drives, pan filter drives and mixers.
- Depends on load requirements.

- Developed to meet the need for a general purpose system capable of interfacing with a variety of inputs, including manual, PLC and process computer to achieve reliable accurate velocity control

- Option for open or closed loop control
- Incorporates user friendly LED indicators
- Accepts noisy 12/24Vdc input
- Input Power Line Surge Suppression

- Dual-Mobile closed-loop controller for applications requiring accurate speed control for motors driven by proportional valves or hydrostatic transmissions
- Includes sprayers, mixers, augers and pump drives

- Controller can be configured as one pulse-pick-up providing the speed command for second loop, thus, regulating spreading in relation to vehicle ground speed

**N/A**

**N/A**

**N/A**

- Easier set-up of LVDT's and DCDT's

- For use with LVDT's synchros & other carrier excited/amplitude modulated transducers
- LVDT Position Decoding

- Summing 2 signals with precision weighting
- Provide stable amplification for low level DC signals such as obtained from strain gages & low speed tachometers

- Used for an accurate force signal when sensing pressure with an unequal area piston

- Dual-Channel Module
- Differential Inputs

- Provides 'on/off' switching outputs that are tripped at settable levels of the DC Input
- LED's provide visual indication of switching

- Set-Point detection
- Null Detection
- "Bang-Bang" Servocontrol

- Logic compatible outputs from Q1 & Q2 can be used for passive pull-downs in a remote logic circuit
- Adjustable time delay for relay switching

*continued next page*

## More Snap Trac Product Line

FUNCTION	MODELS	FEATURES
Ramp Generator	N123-137	<ul style="list-style-type: none"> <li>• Plug-in connectors for quick installation of card</li> <li>• Access to test points for all critical signals</li> <li>• Component stand-offs for field set-up</li> <li>• Adjustable multi-turn control Potentiometers</li> </ul>
I-V Converter	N123-139	<ul style="list-style-type: none"> <li>• Plug-in connectors for quick installation of card</li> <li>• Access to test points for all critical signals</li> <li>• Component stand-offs for field set-up</li> <li>• Adjustable Multi-turn Control Potentiometers</li> <li>• Adjustable Zero and Span</li> <li>• Jumper select I-V conversion options</li> <li>• 4-20mA to 0-10, <math>\pm 10</math>, <math>\pm 5</math>Vdc ranges</li> <li>• Auxiliary Differential Amplifier</li> </ul>
F-V Converter	N123-140	<ul style="list-style-type: none"> <li>• Plug-in connectors for quick installation of card</li> <li>• Access to test points for all critical signals</li> <li>• Component stand-offs for field set-up</li> <li>• Adjustable Multi-turn Control Potentiometers</li> </ul>
Dither Generator	N123-138 • Integral on M121-823	<ul style="list-style-type: none"> <li>• Plug-in connectors for quick installation of card</li> <li>• Access to test points for all critical signals</li> <li>• Component stand-offs for field set-up</li> <li>• Adjustable Multi-turn Control Potentiometers</li> </ul>
Auxiliary Amplifier	<ul style="list-style-type: none"> <li>• Integral on N122-142A / N121-132A</li> <li>• Integral on N123-137 / N123-138</li> <li>• Integral on M121-823</li> </ul>	N/A
Proportional Solenoid Driver	N123-001	<ul style="list-style-type: none"> <li>• Selectable Input Voltage Ranges</li> <li>• Current Offset Adjustments</li> <li>• Adjustable Supply Voltage Range</li> <li>• Output current to 2.0A/dither amplitude to 0.6A</li> </ul>
Mounting Hardware/ Misc./Card Frames	65419-001: PVC Plastic Track/1200mm Length	

## Commissioning, Servicing & Troubleshooting Tools

Valve Testers	M040-104	<ul style="list-style-type: none"> <li>• Battery operated</li> <li>• Full portable with rugged plastic carry case, power supply, analog meters and battery test functions</li> <li>• Capable of testing all Moog electric feedback valves and any mechanical feedback valve with input currents up to 60mA</li> </ul>
	G040-119	<ul style="list-style-type: none"> <li>• Battery operated, compact, lightweight, carry case &amp; cable, CE-Mark</li> <li>• Capable of testing all Moog mechanical feedback servovalves</li> </ul>
	G040-120	<ul style="list-style-type: none"> <li>• Hydraulic test independent of electronics, in-line operation, lightweight and portable, in-built LED spool/pressure meter and special cables available. Test Points for monitoring and CE-Mark</li> <li>• Capable of testing all Moog Servo and Servo-Proportional valves</li> </ul>
	G040-122	<ul style="list-style-type: none"> <li>• Compact design and powered by supply to valve</li> <li>• LED's show level and polarity of signals</li> </ul>
	G040-123	<ul style="list-style-type: none"> <li>• Lightweight and portable</li> <li>• Fixed cables and connectors</li> <li>• Test points to monitor card and spool signals</li> </ul>

## BENEFITS

- Jumper selectable control of internal/external control contains a variable rate Ramp Generator
- Aux Amplifier may be used for low level amplification of a signal or custom modified

- Custom set-up modification capability

- Provides an output voltage proportional to a wide range of frequencies
- A direction control provides signal inversion to give a bi-directional output

- Contains signal generator capable of supplying square & triangular waveforms used for Dither
- Dither used to reduce system threshold caused by actuator and/or servovalve friction

**N/A**

- Dither superimposed on average current waveform to eliminate effects of friction from solenoid valve
- Dead-Band reduction by providing an initial current offset

## APPLICATIONS

- Ramp Generator may be used for acceleration/ deceleration control in a velocity servo
- May be used for velocity control in a position servo or 'Jerk' control in a force loop

- Used to interface between a current output device such as a process controller and a servoamplifier

- Typically used with a magnetic or optical pulse pick-up, to obtain a DC voltage proportional to speed such as engine RPM or motor speed
- Aux Amp used for low level signal amplification

- Dither may be applied to an electrohydraulic servosystem containing valve friction or 'sticking' action

**N/A**

- Designed to drive proportional valves by providing an average current proportional to input command voltage
- Configured as a current mode PWM driver

## COMMENTS

- Accel/Decel Control
- General Purpose Aux Amplifier included

- Power may be available from Model N121-I32A Servocontroller
- Jumper Select options

- Jumper select input frequency range differential input available
- Rugged construction with solder mask

- Factory set for 400Hz frequency with an amplitude of 16Vp-p
- Square wave provides abrupt control from hardover position, whereas Triangular provides softer control response
- Typically adjusted for  $\pm 10\%$  of valve rated current
- Consult Moog catalog for recommended dither frequency/amplitude

**N/A**

- Driver is designed to maintain dither at a minimum amplitude of 0.6A independent of the valve used
- In 2-way proportional solenoid valves, sealing requirements at valve closure create dead-band in the control system

- Commissioning, Monitoring and Battery Operated
- Easy to use

- Simple, inexpensive device for testing of servo-valves

- In-Line Operation, EFB and MFB Valve Monitoring and CE-Mark
- Only one tester is required

- In-line operation, compact and inexpensive
- EFB valve monitoring

- Commissioning / Testing
- Minimizes machine downtime

- Applications requiring in-line monitoring, commissioning, maintenance monitoring and troubleshooting for servo and proportional valves

- For applications requiring commissioning, servicing and troubleshooting control systems that use servo-valves and pump stroker valves with mechanical feedback

- Intended for field checking of complete range of Moog proportional & servovalves; isolates hydraulics from electronic problems

- Intended for complete range of EFB valves on injection molding machines, steel mills, and tube benders

- Intended for field checking of complete range of EFB valves, except for PQ valves

- Units are CE-Marked



# MOOG

# DIN Rail Mount Module Line

FUNCTION	MODELS	FEATURES
Servoamplifier	G122-824	<ul style="list-style-type: none"> <li>• Switch Selectable P and/or I Control</li> <li>• Two Single-Ended Inputs, One Differential</li> <li>• Feedback Transducer Excitation Output</li> <li>• 'In Position' Output</li> <li>• Dither</li> <li>• Enable Input</li> <li>• Switch Selectable Output</li> </ul>
Dual PWM Amp	G123-814	<ul style="list-style-type: none"> <li>• Differential Input</li> <li>• Deadband Compensation, Fixed</li> <li>• Zero Adjustment</li> <li>• Dither</li> <li>• Enable Input</li> <li>• LEDs for Command and Coil Current Levels</li> </ul>
Buffer Amplifier	G123-815	<ul style="list-style-type: none"> <li>• Switch Selectable Valve Drive Filter</li> <li>• Switch Selectable V or I Output</li> <li>• Switch Selectable Current Output Level</li> <li>• LED Valve Drive Indicators</li> <li>• Front Panel Test Points</li> </ul>
Hex Differential Amp	G123-816	<ul style="list-style-type: none"> <li>• 5 Switch Selectable Input Ranges</li> <li>• Differential and/or Single-Ended Inputs</li> <li>• Inverting or Non-Inverting Inputs</li> <li>• Frequency Selectable Anti-Alias Filters</li> <li>• PSC Compatible Output</li> </ul>
Oscillator/Demodulator	G123-817	<ul style="list-style-type: none"> <li>• Oscillator Level and Freq Adjustment</li> <li>• Switch Selectable Secondary Phase Adjust</li> <li>• Voltage and Current Outputs</li> <li>• Output Span and Zero Adjustment</li> <li>• Dual Color LED for Output Monitoring</li> </ul>



## BENEFITS

## APPLICATIONS

## COMMENTS

- User configurable for many different applications
- Front panel access provides fast and easy set-up and aids in troubleshooting
- Compact design

- Drives servovalves or proportional valves in closed-loop systems

- Requires +24Vdc power source
- CE marked

- Front panel trimpots provide quick adjustment of zero and dither
- Compact design

- Drives both coils of a three position 24V solenoid operated proportional valve.
- For use in low end closed-loop systems

- Requires +24Vdc power source
- CE marked

- User friendly configuration.
- Test points and LEDs facilitate commissioning and troubleshooting
- Compact design

- Solves the common problem of interfacing a PLC to a servovalve or proportional valve

- Requires +24Vdc power source
- CE marked

- Direct interface for differential transducers
- Inverting or non-inverting operation
- Compact design

- Conditions six differential signals into six single-ended +/- 10V signals suitable for the Moog PSC analog inputs

- Requires +24Vdc power source
- CE marked

- Phase monitoring circuits ensure quick and reliable set-up
- Front panel test point enables measurement of oscillator level and frequency

- Used in conjunction with an LVDT to convert transducer mechanical position to a DC voltage of +/- 10V and a DC current of 4-20mA

- Requires +24Vdc power source
- CE marked

# Open-Loop Position Control

An open-loop load positioning system uses a servovalve, an actuator, an input command generator (potentiometer or other) and a servoamplifier. The two output control ports on the servovalve are connected to the actuator.



A system is deemed open-loop control when there is a human operator monitoring the output parameter (such as position or speed) and varying the input command generator, thus controlling the input to the servovalve to obtain the desired result.

Shown to the right is a typical linear position system using a single-ended piston. Rotary position systems can be created by substituting the appropriate rotary components.



## EUROCARD

### Suggested Setup Procedures:

(Reference Moog Document G122-202A1)

1. Turn off hydraulic power and relieve pressure.
2. Adjust the GAIN pot (P2) to minimum by turning full counter-clockwise.
3. Apply electrical power.
4. Adjust the BIAS pot (P1) for zero coil current at midstroke of the command pot.
5. Apply hydraulic power.
6. Adjust the GAIN pot (P2) for the desired sensitivity of the command pot.

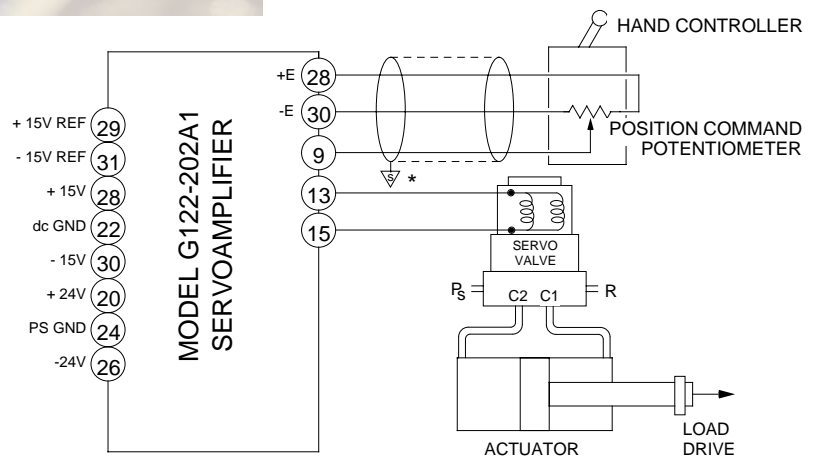

Power supplied by common power bus in the 19 inch rack.

\* Ground shields at servoamplifier end only.

### Modifications to the G122-202A1 card:

(Reference Moog Document G122-202A1)

- Set PID for P control
- Set I/U jumper in "I" position for current drive



## SNAP TRAC

### Suggested Setup Procedures:

(Reference Moog Document NI21-132A)

1. Turn off hydraulic power and relieve pressure.
2. Adjust the GAIN pot (R4) to minimum by turning full counter-clockwise.
3. Apply electrical power.
4. Adjust the BIAS pot (R16) for zero coil current at midstroke of the command pot.
5. Apply hydraulic power.
6. Adjust the GAIN pot (R4) for the desired sensitivity of the command pot.

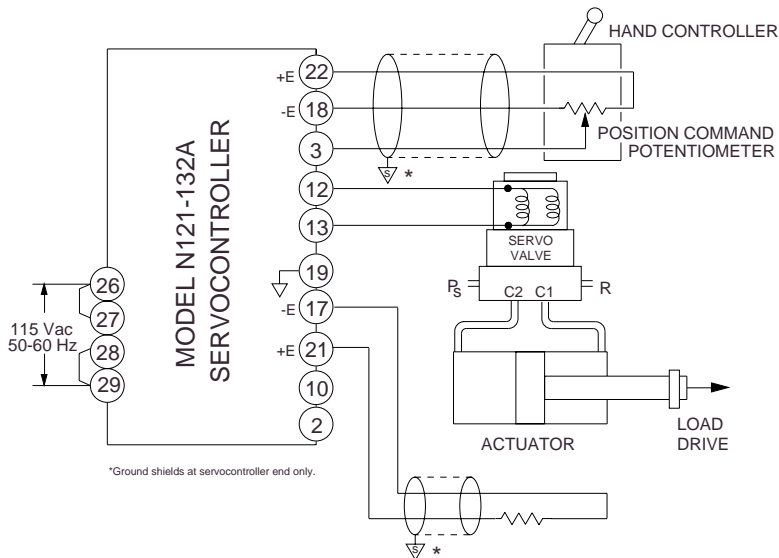

### Modifications to the NI21-132A card:

- Set for proportional (P) control only
- Set current/voltage mode jumper to "off" (current drive)



# Closed-Loop Position Control

(2-stage valve)

A closed-loop, load positioning system uses a high performance control valve, an input command generator (potentiometer or other), a servoamplifier, an actuator and a position transducer to monitor the output location, eliminating the need for human observation. The two output control ports of the valve are connected across the actuator.



In the servoamplifier, the command input is compared to the present position output of the feedback transducer. If a difference between the two exists, it is fed to the servovalve as an error signal. This signal shifts the valve spool position, adjusting flow to the actuator until the feedback position output agrees with the command input, and the desired physical position is achieved or maintained.

The servoamplifier and a DC position transducer, such as a DCDT or linear potentiometer, can be used to create a closed-loop position controller capable of fast, accurate control.

## EUROCARD

### Suggested Setup Procedures:

(Reference Moog Document G122-202A1)

1. Turn off hydraulic power and relieve pressure.
2. Set the GAIN pot (P2) on the G122-202A1 card approximately five turns from full counter-clockwise.
3. Set the SCALE pot (P9) on the G122-202A1 card full counter-clockwise.
4. Apply electrical power.
5. On the G122-202A1 card, temporarily remove the feedback connection from terminal [3]. Adjust the BIAS pot (P1) for zero coil current at midstroke of the command pot. Re-connect terminal [3].
6. Apply hydraulic pressure. If the actuator extends fully hardover, reverse terminals [13] and [15].
7. Increase the GAIN pot (P2) clockwise until the system exhibits the desired sensitivity. Check the stability of the system throughout the full load range.
8. Adjust the BIAS pot (P1) for mid actuator position at zero command signal, or as desired.

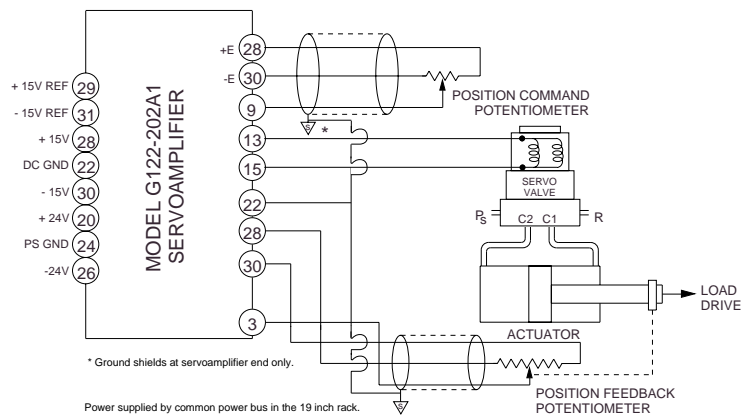

### Modifications to the G122-202A1 card:

(Reference Moog Document G122-202A1)

- Set PID for P control
- Set I/U jumper in "I" position for current drive



## SNAP TRAC

### Suggested Setup Procedures:

(Reference Moog Document NI21-132A)

1. Turn off hydraulic power and relieve pressure.
2. Set the GAIN pot (R4) on the NI21-132A card approximately five turns from full counter-clockwise.
3. Set the SCALE pot (R9) on the NI21-132A card full counter-clockwise.
4. Apply electrical power.
5. On the NI21-132A card, temporarily remove the feedback connection from terminal [2]. Adjust the BIAS pot (R16) for zero coil current at midstroke of the command pot. Re-connect terminal [2].

6. Apply hydraulic pressure. If the actuator extends fully hardover, reverse terminals [12] and [13].
7. Increase the GAIN pot (R4) clockwise until the system exhibits the desired sensitivity. Check the stability of the system throughout the full load range.
8. Adjust the BIAS pot for mid actuator position at zero command signal, or as desired.

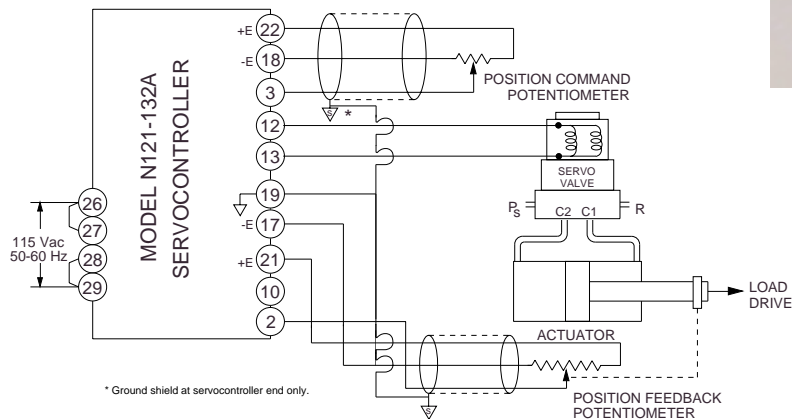

### Modifications to the NI21-132A card:

(Reference Moog Document NI21-132A)

- Set the jumpers for proportional control only
- Set mode jumper to "off" (current drive)

# Closed-Loop Position Control

(3-stage valve)

Three-Stage servovalves are used in applications where high flow is required. The following examples illustrate the use of an Exciter/Demodulator card to configure the three-stage servovalve LVDT for inner loop servo control.



The DC voltage from the Exciter/Demodulator is proportional to the position of the servovalve third-stage spool. The DC voltage, the servoamplifier and the signal from a position feedback transducer create a position servo controller. The inner loop gain can be adjusted independent of the outer loop gain.

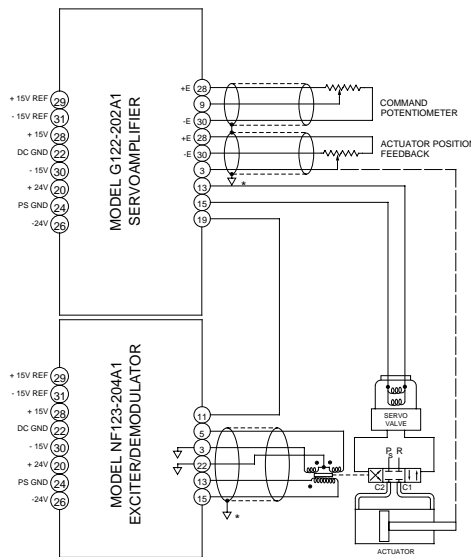

\* Ground shields at servoamplifier end only.

Power supplied by common power bus in the 19 inch rack.

## EUROCARD

### Suggested Setup Procedure:

(Reference Moog Documents G122-202A1 & NF123-204A1)

1. Turn off hydraulic power and relieve pressure.
2. Set the GAIN pot (P2) on the G122-202A1 card approximately five turns from full counter-clockwise.
3. Set the SCALE pot (P9) on the G122-202A1 full clockwise.
4. Select resistor valve for position Z4 to give proper inner loop gain of three-stage valve.
5. Apply electrical power.
6. On the G122-202A1 card, temporarily remove the feedback connection from terminals [3] and [19]. Adjust the BIAS pot (P1) for zero coil current with pin 9 grounded. Re-connect terminal [3]. Set the SCALE pot (P9) on the G122-202A1 full counter-clockwise.
7. Apply hydraulic pressure.
8. Adjust the NF123-204A1 Exciter/Demodulator card for proper demodulator GAIN (P3) by monitoring the voltage at terminal [11]. Adjust the NF123-204A1 output BIAS pot (P4) for zero volts with the valve at null (zero current drive to the valve).
9. Re-connect terminal [19] of the G122-202A1 card.
10. Increase the G122-202A1 GAIN pot (P2) clockwise until the system exhibits the desired sensitivity. Check the stability of the system throughout the full load range.
11. Adjust the G122-202A1 BIAS pot (P1) for mid actuator position at zero command signal, or as desired.

### Modifications to the G122-202A1 card:

(Reference Moog Document G122-202A1)

- Set PID for P control
- Set I/U jumper for current drive
- Calculate proper resistor valve for "Z4" to yield desired inner loop gain of three-stage valve. Insert resistor in position Z4

## SNAP TRAC

### Suggested Setup Procedure:

(Reference Moog Documents NI21-132A and NI23-134)

1. Turn off hydraulic power and relieve pressure.
2. Set the GAIN pots (R4 and R43) on the NI21-132A card approximately five turns from full counter-clockwise.
3. Set the SCALE pot (R9) on the NI21-132A card full clockwise.
4. Apply electrical power.
5. On the NI21-132A card, temporarily remove the feedback connection from terminals [2] and [6]. Adjust the BIAS pot (R16) for zero coil current at midstroke of the command pot. Re-connect terminal [2].

6. Apply hydraulic pressure.
7. Adjust the NI23-134 Exciter/Demodulator card for proper GAIN (R5) and PHASE (R16) by monitoring the voltage at terminal [12].
8. Re-connect terminal [6] of the NI21-132A card. Turn the SCALE pot (R9) full counter-clockwise.
9. Increase the GAIN pots (R4, R43) clockwise until the system exhibits the desired sensitivity. Check the stability of the system throughout the full load range.
10. Adjust the BIAS pot (R16) for mid actuator position at zero command signal, or as desired.

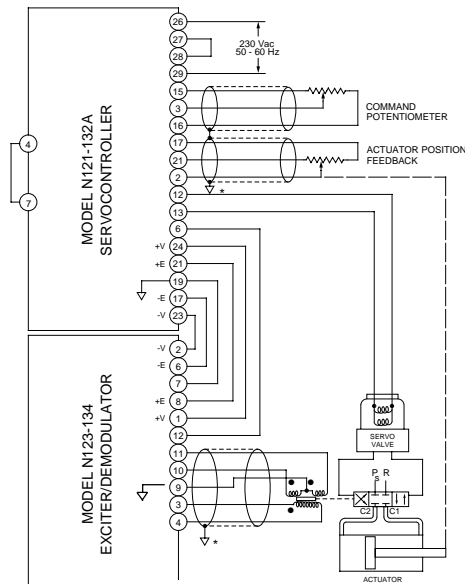

\* Ground shield at servocontroller end only.

### Modifications to the NI21-132A card:

(Reference Moog Document NI21-132A)

- Set the jumpers for proportional control only
- Insert R45=20K $\Omega$



# Force Control with a Proportional Servovalve

A closed loop force control system is made up of a control valve, an actuator, a load cell or pressure transducer and a servoamplifier. The two output control ports on the control valve are connected across the load actuator.

In the servoamplifier, the command input is compared to the present pressure in the



actuator ports (Force = Area x Pressure). If a difference between the two exists, it is amplified and fed to the control valve. This signal shifts the valve spool position, adjusting pressure in the actuator until the force output agrees with the command input.

The Signal Conditioner card can be used to process pressure signals and obtain a force feedback signal from the actuator. Strain gauge type pressure transducers are often used in such applications. The signal conditioning provides stable amplification of the millivolt-level strain gauge outputs. DC voltmeters can be connected to provide visual indication of the hydraulic pressures.

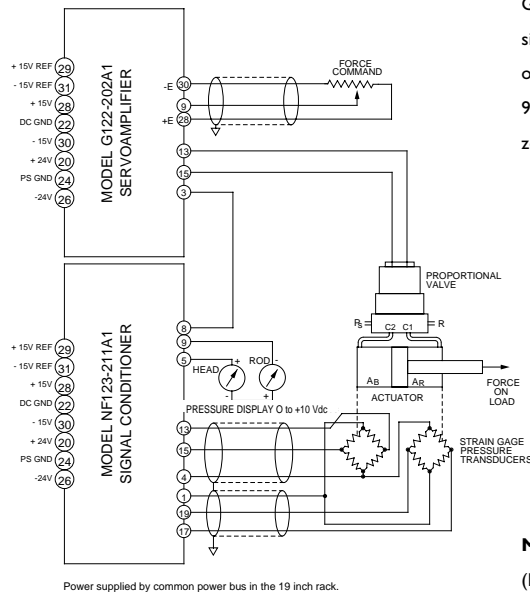

## EUROCARD

Using Voltage Driven Control Valve

### Suggested Setup Procedure:

(Reference Moog Document G122-202A1 and

NF123-211A1)

1. Turn off hydraulic power, relieve pressure.
2. Set the GAIN pot (P2) on the G122-202A1 card approximately five turns from full counter-clockwise.
3. Set the SCALE pot (P9) on the G122-202A1 card full counter-clockwise.
4. Apply electrical power.
5. Apply hydraulic pressure.
6. If unequal area scaling is required, adjust the ZERO pots (P6, P7) and SPAN pots (P4, P5) on the NF123-211A1 card for corresponding pressures from the strain gauge transducers. Set  $b=1$  by setting P3 full clockwise. Set  $a=A_R/A_B$  by setting P2 until voltage at  $a=A_R/A_B$  (voltage Pin 5).
7. Adjust the BIAS pot (P1) on the G122-202A1 card for zero voltage at minimum setting of the FORCE command pot.
8. Set the GAIN pot (P2) and SCALE pot (P9) on the G122-202A1 card for the desired force vs command signal range. Check the stability of the system through out the full load range.
9. Re-set the BIAS pot (P1) on the G122-202A1 for zero force corresponding to zero command signal.

### Modifications to the G122-202A1 card:

(Reference Moog Document G122-202A1)

- Set PID for P control
- Set I/U jumper in "U" position for voltage drive

# SNAP TRAC

Using Voltage Driven Control Valve

## Suggested Setup Procedure:

(Reference Moog Document NI21-132A and NI23-135)

1. Turn off hydraulic power, relieve pressure.
2. Set the GAIN pots (R4) on the NI21-132A card approximately five turns from full counter-clockwise.
3. Set the SCALE pot (R9) on the NI21-132A card fully clockwise.
4. Apply electrical power.
5. Apply hydraulic pressure.



6. If unequal area scaling is required, adjust the ZERO pots (R8, R30) and SPAN pots (R3, R27) on the NI23-135 card for corresponding pressures from the strain gauge transducers.
7. Adjust the BIAS pot (R16) on the NI21-132A card for zero voltage at minimum setting of the FORCE command pot.
8. Set the GAIN pot (R4) and SCALE pot (R9) for the desired force vs command signal range. Check the stability of the system throughout the full load range.
9. Set the BIAS pot (R16) for zero force corresponding to zero command signal.

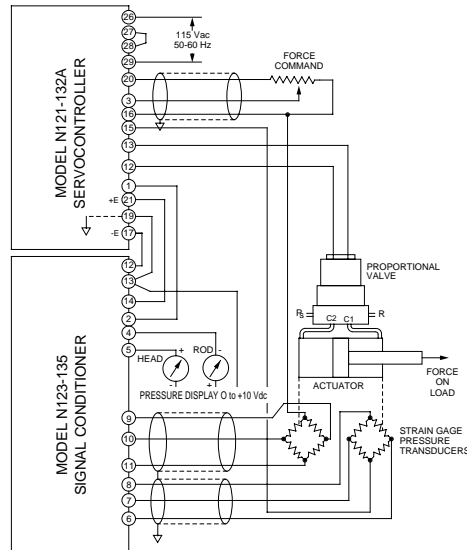

## Modifications to the NI21-132A card:

(Reference Moog Document NI21-132A)

- Set the jumpers for proportional control only
- Set jumper JMPRI for voltage drive



# Closed Loop Velocity Control

(with acceleration limit)

Closed-loop velocity control with acceleration limit can be achieved through the use of a servoamplifier. Typically, a packaged rotary servomotor is used and the velocity is measured by a DC tachometer driven directly or through gearing from the back of the motor shaft. The velocity command signal is obtained



from a potentiometer or a command source such as a Programmable Logic Controller (PLC). Integral control is used for improved speed tracking performance.

Moog Technical Bulletin (TBI22) contains a detailed summary of sizing criteria and performance characteristics of velocity servos using servomotors.

In these examples, the Current to Voltage Converter is used to interface with the 4mA to 20mA current command source from a PLC to the voltage input of the servoamplifier.

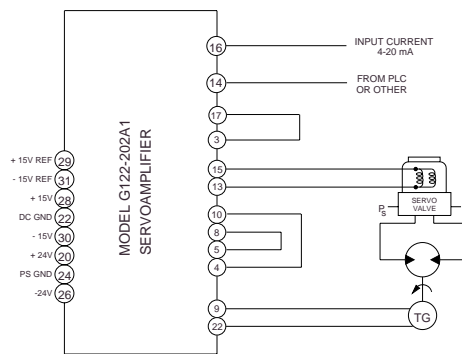

Power supplied by common power bus in the 19 inch rack.

## EUROCARD

### Suggested Setup Procedure:

(Reference Moog Documents G122-202A1)

1. Turn off hydraulic power and relieve pressure.
2. Disconnect the tachometer lead from terminal 9 on the G122-202A1 card.
3. Set the GAIN pot (P2) and the INTEGRATOR pot (P5) on the G122-202A1 card approximately five turns from full counter-clockwise.
4. Set the SCALE pot (P9) on the G122-202A1 card full counter-clockwise.
5. Apply electrical power.
6. Re-connect the tachometer lead to terminal 9 on the G122-202A1 card.
7. Adjust the GAIN by setting pot (P2) full counter clockwise and adjusting pot (P5) for stability. If pot P5 is at full clockwise and more GAIN is desired, back pot P5 five turns off full clockwise and adjust pot P2 clockwise until the response is achieved.
8. Set the SCALE pot (P9) on the G122-202A1 card for desired speed range vs command signal range. Check the stability of the system throughout full speed and load range.
9. Adjust the BIAS pot (P1) on the G122-202A1 card for zero load speed at zero command input.

### Modifications to the G122-202A1 card:

(Reference Moog Document G122-202A1)

- Set PID jumpers for I control
- Set jumper JMPR1 for current drive
- It may be desirable to activate solenoid to short out integrator when commanding "0" RPM

## SNAP TRAC

### Suggested Setup Procedure:

1. Turn off hydraulic power and relieve pressure.
2. Set the GAIN pot (R4) and the INTEGRATOR pot (R58) on the NI21-132A card approximately five turns from full counter-clockwise.
3. Set the SCALE pot (R9) on the NI21-132A card fully clockwise.
4. Remove the tachometer connection from terminal [3] on the NI21-132A card.
5. Apply electrical power.
6. Adjust ZERO (R8) and SPAN (R11) on the NI23-139 card so that 4-20 mA input corresponds to  $\pm 10$  V output to the NI21-132A card. Refer to the NI23-139 line card.

7. Re-connect the tachometer lead to terminal [3] on the NI21-132A card.
8. Adjust the GAIN pot (R4) and (R58) on the NI21-132A card for maximum (clockwise) with stable controller coil current (no oscillation).
9. Set the SCALE pot (R9) on the NI21-132A card for desired speed range vs command signal range. Check the stability of the system throughout full speed and load range.
10. Adjust the BIAS pot (R16) on the NI21-132A card for zero load speed at zero command input.

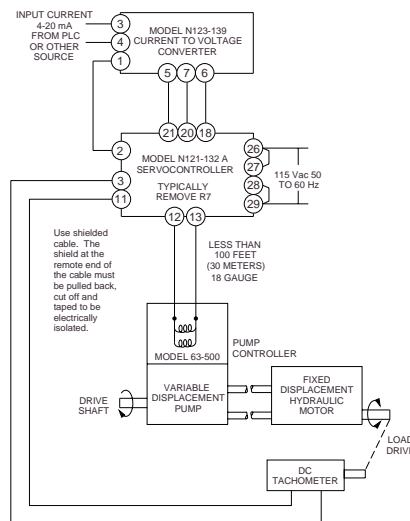

### Modifications to the NI21-132A card:

(Reference Moog Document NI21-132A)

- Set PID jumpers for I control
- Set jumper JMPRI for current drive
- It may be desirable to activate solenoid to short out integrator when "0" RPM is commanded



# Two Axis Programmable Logic Controller

(PLC Servosystem)

A two-axis system can be configured so that all analog signal processing takes place using electronics, in order to utilize a controller having only discrete inputs/outputs.

For the linear Y-axis servo, the Current to Voltage Converter interfaces between the 4mA-20mA current command source from a



Programmable Logic Controller (PLC) and the voltage input of the Ramp Generator. The Ramp Generator provides variable acceleration/ deceleration control in response to a step input. The servoamplifier, in conjunction with the position feedback transducer and conditioning electronics, provides closed-loop control of the valve and actuator. In addition, the servoamplifier provides DC source power to all analog servo electronics.

## EUROCARD

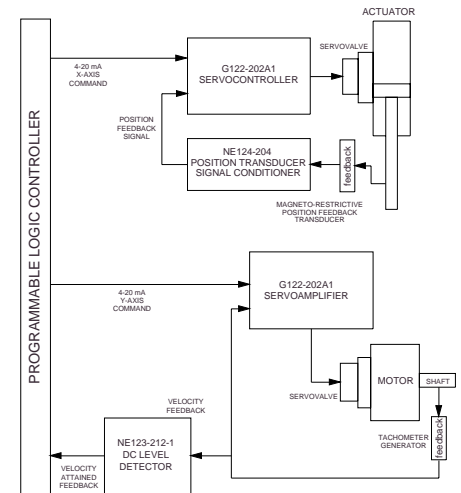

**Suggested Setup Procedure:** Consult the Factory.

**Note:** The Current to Voltage Converter and the Ramp Generator are designed into the G122-202A1 Servoamplifier.



## SNAP TRAC

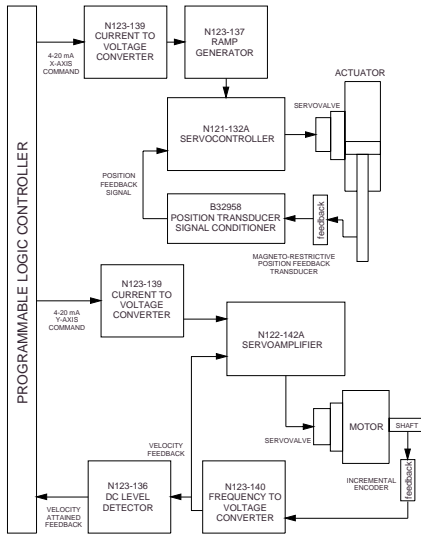

**Suggested Setup Procedure:** Consult the Factory.

The rotary X-axis uses a Current to Voltage Converter as an interface between the PLC and the servoamplifier, which consequently provides closed-loop control of the valve/motor drive. The Frequency to Voltage Converter card decodes the pulsed output of the incremental encoder, and provides a DC output feedback voltage proportional to the rotational speed of the motor. The DC Level Detector is configured to trip at a preset feedback voltage level to provide feedback to the PLC when the desired motor speed has been obtained.





Moog's engineers are trained in the theory and practice of servo systems and can carry out detailed studies (often computer assisted) to predict the performance of your closed-loop system. Contact the Factory for more information on this service.



## A WORD OF CAUTION

Stability of a closed-loop control system, with adequate performance, is often difficult to achieve. Each component may perform perfectly, yet connecting the components into a closed-loop can result in unacceptable behavior such as hunting, oscillation, inordinate overshoot, chatter, sluggishness, poor resolution, hardover, drift or catastrophic breakdown of a pressure-containing component. Unacceptable closed-loop behavior may be a result of the type of load, length of hydraulic lines, sizing of valve and actuator, loop gains, presence of backlash, friction, load limiters, compliance, location of electronics or transducers relative to magnetic fields, shock or vibration. Other system idiosyncrasies can contribute to the unacceptable behavior.

Due to the wide spectrum of variables for each application, Moog cannot ensure the performance of closed-loop control systems. Exercise extreme caution upon initial system power-up or component adjustment to avoid personal injury or equipment damage resulting from an unexpected condition.



Customize your control system with Moog's Servo Electronics. Our Eurocard, Snap Trac, DIN Rail module and Transducer selections provide solutions for a wide variety of servocontrol needs. Our highly skilled Engineering Department can assist and analyze the performance of your closed-loop system. Contact us at Moog, or an authorized Moog distributor, to find out how we can help your system operate at peak performance.

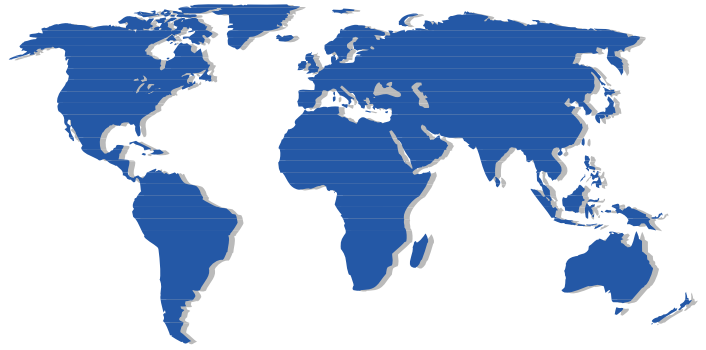

Argentina  
Australia  
Austria  
Brazil  
China  
Finland  
France  
Germany  
India

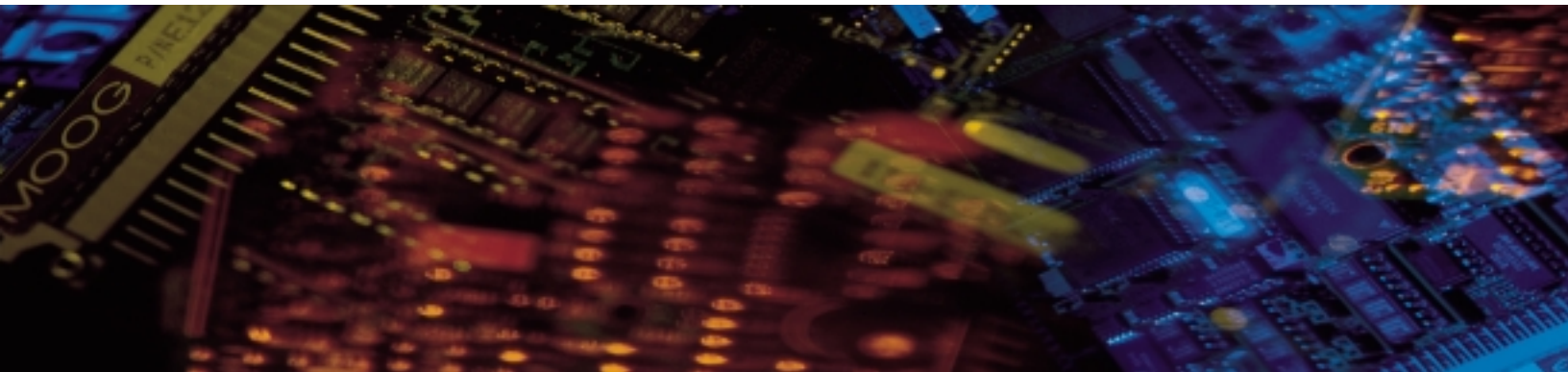

Ireland  
Italy  
Japan  
Korea  
Luxembourg  
Norway  
Russia  
Singapore  
Spain  
Sweden  
United Kingdom  
USA

**MOOG**  
**Industrial Controls Division**  
Moog Inc., East Aurora, NY 14052-0018  
Telephone: 716/655-3000  
Fax: 716/655-1803  
Toll Free: 1-800-272-MOOG  
[www.moog.com](http://www.moog.com)