

FLUID COOLING | Mobile DF Series

AIR COOLED DF

Features

- Same as DH with DC Fan
- 3/4" Tube Size
- Low AMP Draw 12 or 24 Volt DC Motors
- Heavy Duty Construction
- Optional Serviceable Relief Bypass Valve
- Optional Fan Control Switch
- Long Life Hydraulic Motors
- Rugged Applications
- Steel Manifolds
- Heat Removal TO 35,000 BTU/Hr.
- Oil Flows to 110 GPM
- Mounting Brackets Included
- SAE, NPT or 37° Flare Oil Connections
- Damage Resistant Steel Fins

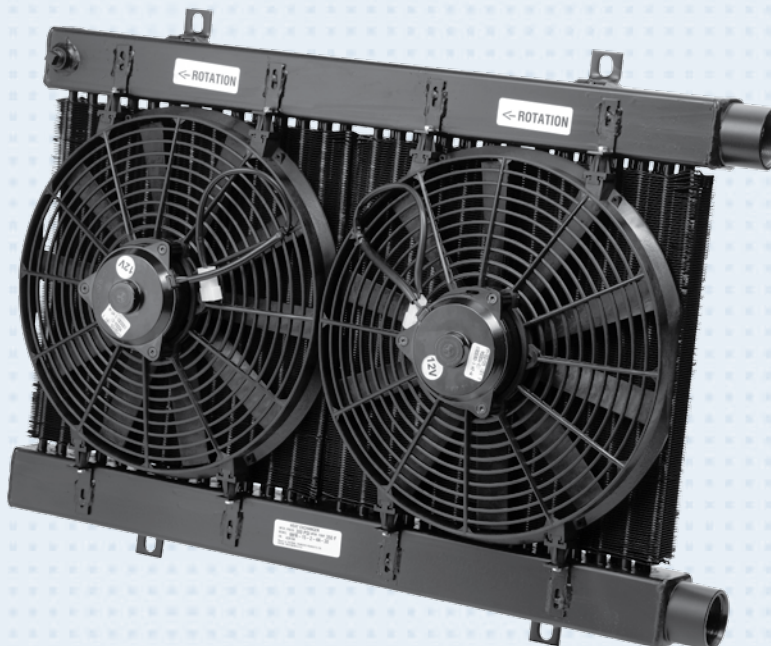

Ratings

Operating Pressure 300 psi
Test Pressure 300 psi
Operating Temperature 350° F

Materials

Tubes Copper
Fins Steel
Turbulators Aluminum
Manifolds Steel
Fan Assembly High Impact Plastic
Motor Displacement .22in³/Rev. (Hydraulic)
Maximum Pressure 2000 PSI (Hydraulic)
Allowable Backpressure 1000 PSI (Hydraulic)

Relief Bypass Valve Option

MODEL	DESCRIPTION
DFR-11	3/4", external, all steel valve. Available in either 30 PSI or 60 PSI settings. May be removed for servicing.
DFR-12	1-1/2", external, all steel valve.
DFR-22	Available in either 30 PSI or 60 PSI settings. May be removed for servicing.

Number of Fans	DC current required		Hydraulic Motor Data		
	12 Volt	24 Volt	Oil Flow Required (GPM)	Minimum Operating Pressure (PSI)	Maximum Fan Speed (RPM)
1	12.5 amps	6.3 amps	2.1	300	2200
2	25 amps	12.6 amps	4.2	300	2200

How to Order

-
 -
 -
 -

Model Series
DF
DFR - Relief Bypass Included

Model Size Selected

Connection Type*
1 - NPT
2 - SAE
3 - BSPP
7 - 37° Male Flare

Motor Specification
NM - No Motor
4A - 12 Volt DC
4B - 24 Volt DC
9 - Hydraulic Motor

Relief Bypass
Blank - No Bypass
30 - 30 psi
60 - 60 psi

ADD FOR DFR MODELS ONLY

*Other connection types available. Please consult factory for assistance.

Dimensions - 12 & 24 Volt DC Motors

Models DF-11 and DF-12

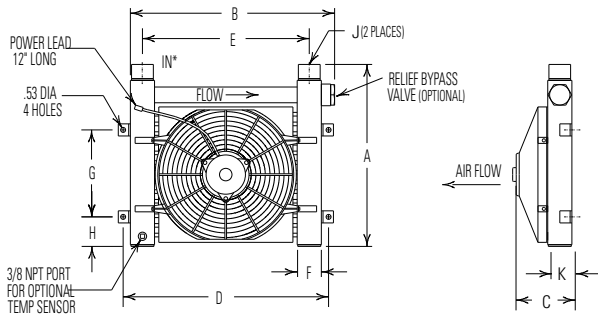

Model DF-22

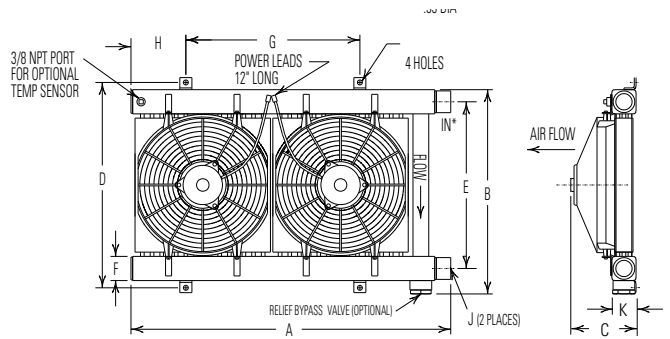

Units shown with optional bypass valve

MODEL	A		B		C	D	E	F	G	H	J		K	LBS
	DF	DFR	DF	DFR							NPT	SAE		
DF-11	16.12	18.00	19.25	20.91	5.51	20.75	17.75	1.50	7.50	3.69	1.00	#16	1.50	38
DF-12	17.00	18.25	21.25	22.91	7.01	22.75	18.75	2.50	14.25	7.69	1.50	#24	3.00	110
DF-22	31.47	33.73		22.62										

Note: All dimensions are in inches. We reserve the right to make reasonable design changes without notice. *Inlet and outlet oil connections can be reversed when the bypass valve is not used.

Dimensions - Hydraulic Motors

Models DF-11 and DF-12

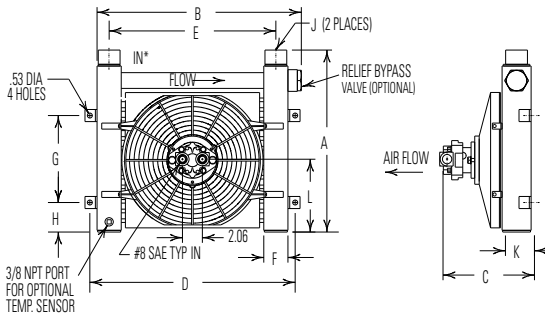

Model DF-22

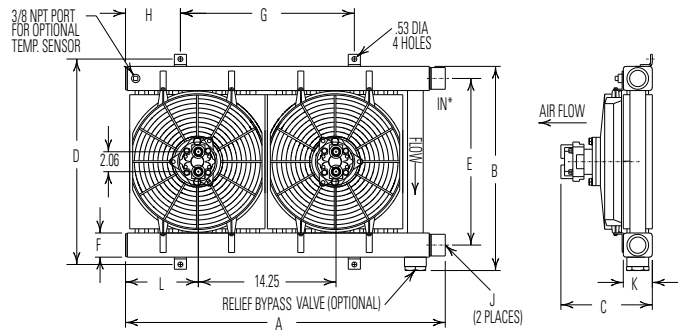

Units shown with optional bypass valve

MODEL	A		B		C	D	E	F	G	H	J		K	L	LBS
	DF	DFR	DF	DFR							NPT	SAE			
DF-11	16.12	18.00	19.25	20.91	7.47	20.75	17.75	1.50	7.50	3.69	1.00	#16	1.50	7.56	38
DF-12	17.00	18.25	21.25	22.91	9.46	22.75	18.75	2.50	14.25	7.69	1.50	#24	3.00	7.60	110
DF-22	31.47	33.73		22.62											

Note: All dimensions are in inches. We reserve the right to make reasonable design changes without notice. *Inlet and outlet oil connections can be reversed when the bypass valve is not used.

Performance Curves

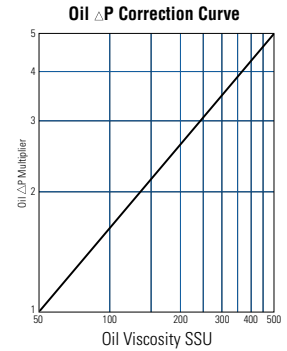
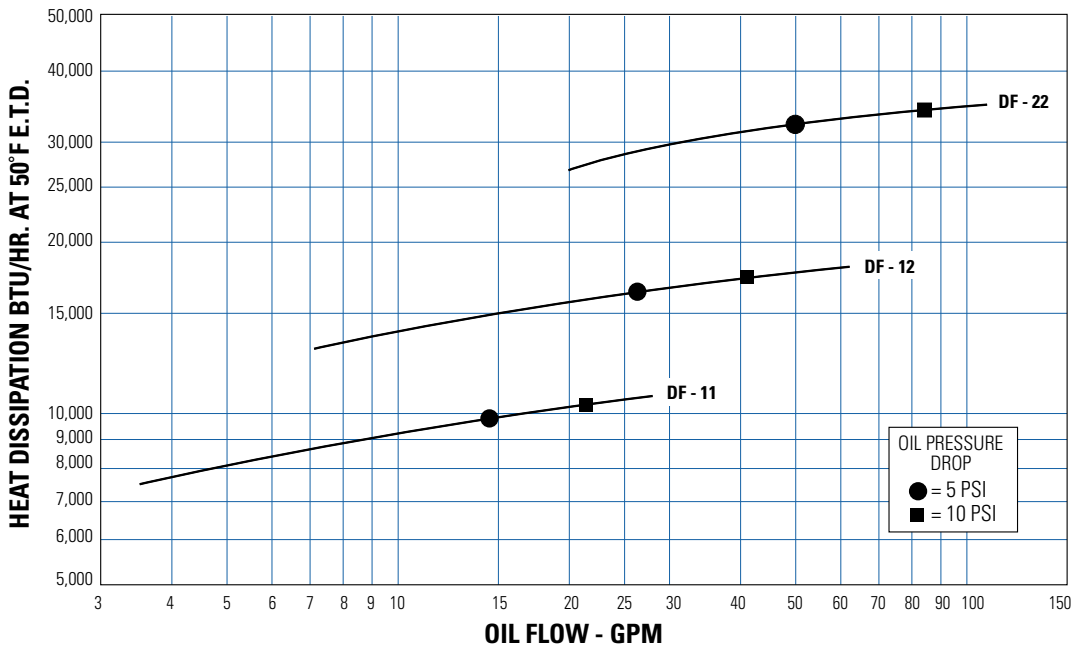

Selection Procedure

Performance Curves are based on 50 SSU oil entering the cooler 50°F higher than the ambient air temperature used for cooling. This is referred to as a 50°F E.T.D.

Step 1 Determine the Heat Load. Heat load may be expressed as either horsepower or BTU/Hr. To convert horsepower to BTU/Hr.:
 BTU/HR = Horsepower x 2545

Step 2 Determine Entering Temperature Difference. The entering oil temperature is generally the maximum desired oil temperature.
 Entering oil temperature – Ambient air temperature = E.T.D.

Step 3 Determine the Corrected Heat Dissipation to use the curves.
 Corrected Heat Dissipation = BTU/HR heat load x $\frac{50^\circ\text{F} \times C_v}{\text{E.T.D.}}$

Step 4 Enter curves at oil flow through cooler and curve heat dissipation. Any curve above the intersecting point will work.

Step 5 Determine Oil Pressure Drop from Curves:
 ● = 5 PSI; ■ = 10 PSI; Multiply pressure drop from curve by correction factor found in oil ΔP correction curve.

Oil Temperature

Typical operating temperature ranges are:

Hydraulic Motor Oil	120°F - 180°F
Hydrostatic Drive Oil	160°F - 180°F
Engine Lube Oil	180°F - 200°F
Automatic Transmission Fluid	200°F - 300°F

C_v Viscosity Correction

Average Oil Temp °F	OIL				
	SAE 5 110 SSU at 100°F 40 SSU at 210°F	SAE 10 150 SSU at 100°F 43 SSU at 210°F	SAE 20 275 SSU at 100°F 50 SSU at 210°F	SAE 30 500 SSU at 100°F 65 SSU at 210°F	SAE 40 750 SSU at 100°F 75 SSU at 210°F
100	1.14	1.22	1.35	1.58	1.77
150	1.01	1.05	1.11	1.21	1.31
200	.99	1.00	1.01	1.08	1.10
250	.95	.98	.99	1.00	1.00

Thermostatic Temperature Control Option (DC)

This controller was designed to mount on the cooler without requiring extensive wiring or plumbing. It provides accurate temperature control by cycling the cooling fan(s) to maintain desired oil temperature.

- 12 or 24 volt operation
- Adjustable temperature settings range from 100°F thru 210°F in 20°F increments
- For use with one or two fan models
- Temperature sensor provided
- Wiring provided for remote manual override
- Mounting hardware included

Part Number	Description
96171	Electronic Fan Control Kit
68790	Replacement Control Only
67699	Replacement Sensor Only

Side View

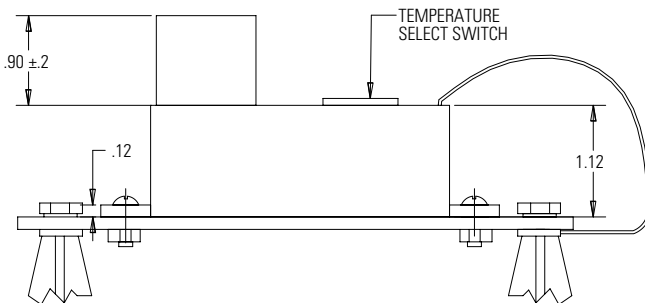

Connection Assembly

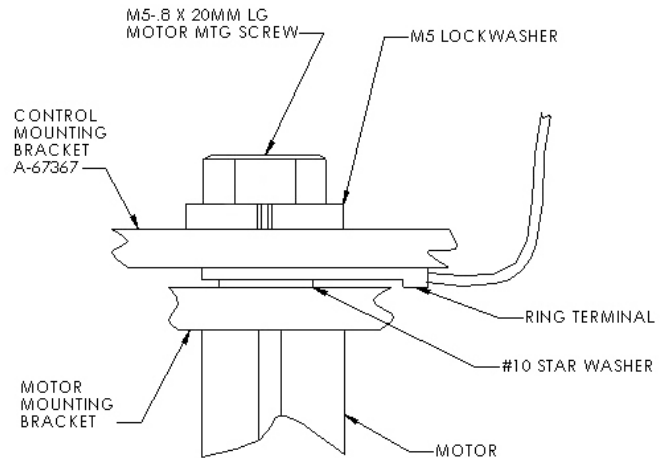

Top View

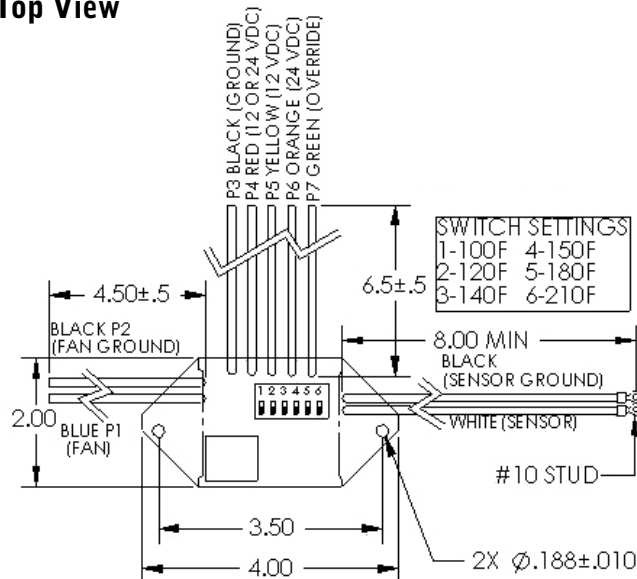

Electrical Schematic

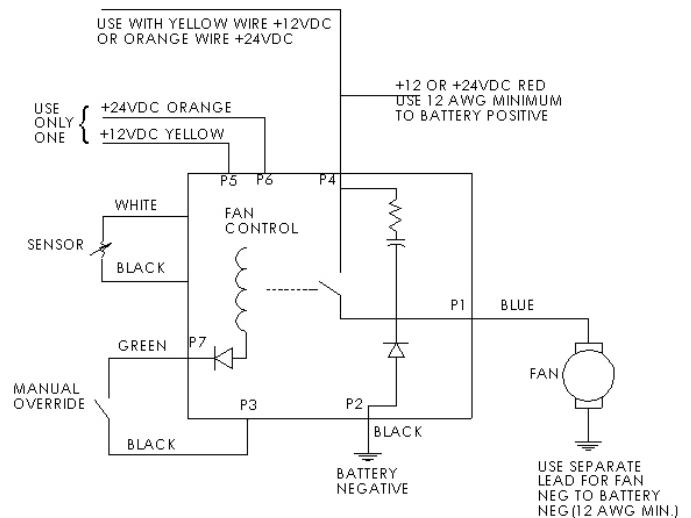

NOTE: This switch should be fused to prevent damage if ground is lost. A 30 amp fuse is required in the power supply.